

FSG010

Fire sprinkler pressure gauge

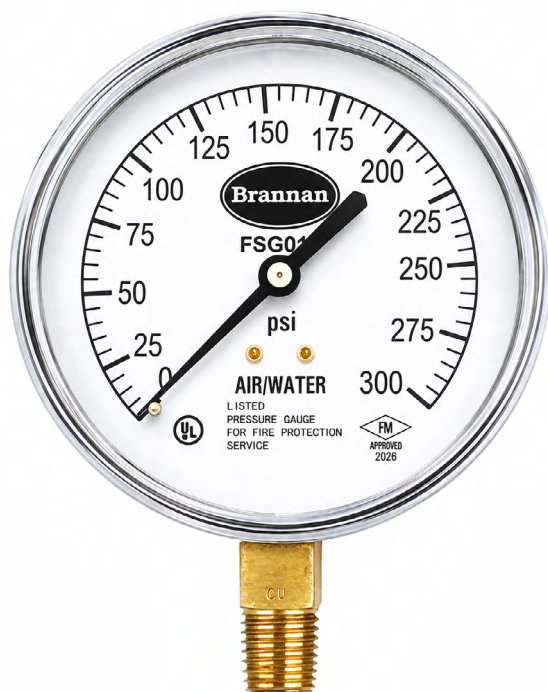

Product features:

- UL-listed (UL-393)
- Factory Mutual (FM) approved
- Dual scale or single scale
- ASME B40.100 compliant
- UKAS calibration available

Applications:

- Fire protection industry
- Wet or dry sprinkler systems
- 0 to 80 psi retarded to 250 psi gauge is generally used on the sprinkler head side of the control valve to monitor air line pressure
- The 0 to 300 psi gauge is generally used on the water supply side of the system to indicate available source pressure

Standard product specifications:

Standards & categories	
Approval	FM® and UL®; Factory Mutual System and listed by Underwriter's Laboratories
Design	ASME B40.100
Gauge construction	
Case	Black plastic resin (PC-PBT corrosion resistant)
Dial	Galvalume
Connection orientation	Bottom
Connection material	Brass
Pointer	Black aluminium
Measuring principle	Phosphor bronze
Movement	Brass
Window	Polycarbonate one-piece threaded
Ranges & parameters	
Dial diameter	3.5" (90mm)
Range	0 to 80 psi retarded to 250 psi or 0 to 300 psi (other units available on request)
Thread size	1/4" NPT
Accuracy class	±3-2-3% (Grade B)
Filling	Dry
Working pressure	Steady: 75% full scale range, fluctuating: 60% full scale range, short time: full scale range
Operating temperature	-40 to +65°C (-40 to +150°F)
Storage temperature	-40 to +65°C (-40 to +150°F)
Protection	IP 52
Optional extras	
Calibration	UKAS certification, certificate traceable to recognised national standard or statement of conformity

FSG010

✉ sales@brannan.co.uk

☎ +44 (0)1946 816600

🌐 brannan.co.uk

Fire sprinkler pressure gauge

Product dimensions:

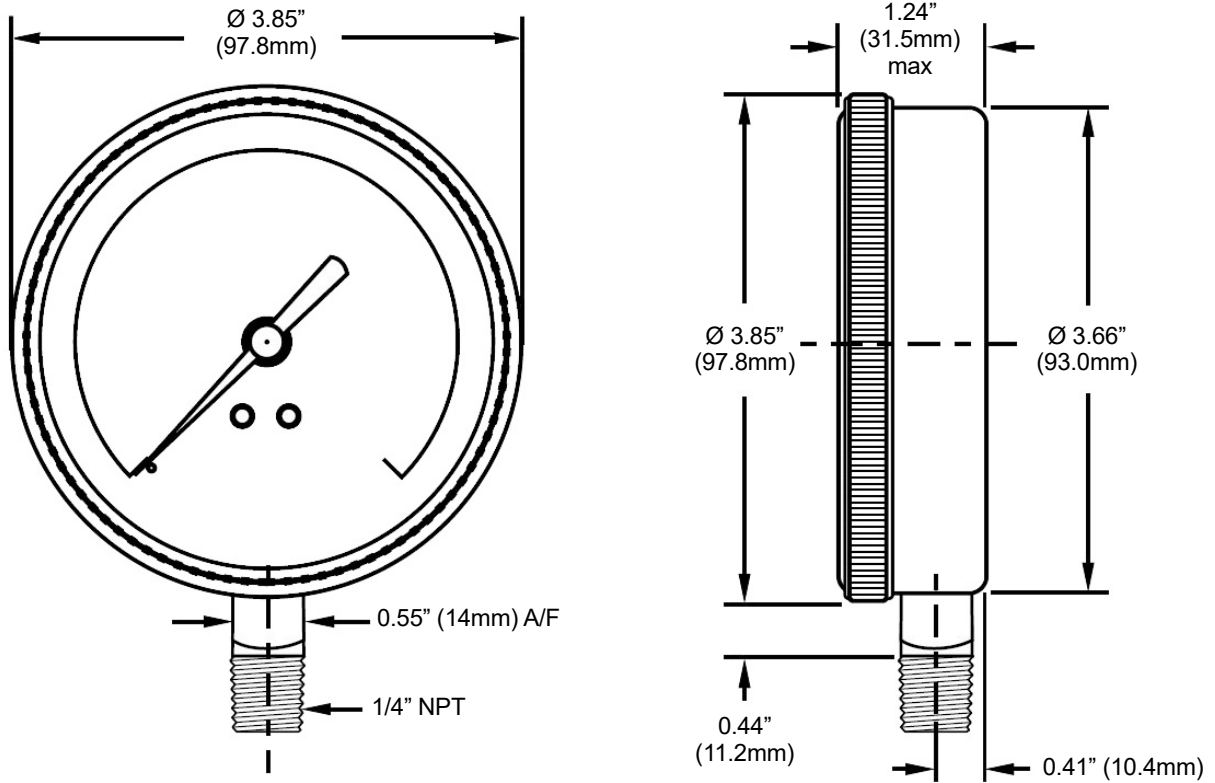

Approx weight:

Supplied in individual box with operating instructions.

Net weight: 185.5g

Box weight: 20.5g

Gross weight: 207.0g

Standard product numbers:

Range	Air	Water	Air/Water
0 to 80 psi (Retarded to 250 psi)	36/500/0	-	-
0 to 80 psi & bar (Retarded to 250 psi / bar)	36/500/1	-	-
0 to 80 psi & kPa (Retarded to 250 psi / kPa)	36/500/2	-	-
0 to 300 psi	-	36/501/0	36/502/0
0 to 300 psi & bar	-	36/501/1	36/502/1
0 to 300 psi & kPa	-	36/501/2	36/502/2