

Product data sheet

✉ sales@brannan.co.uk

☎ +44 (0)1946 816600

🌐 brannan.co.uk

WT010 - STEEL CASED HOT WATER THERMOMETERS

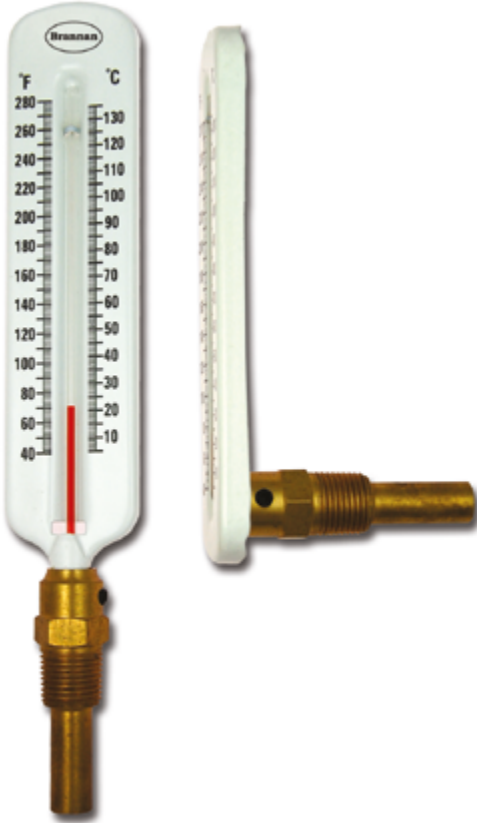

Features:

- Low price glass thermometer
- Easy to install
- Separate brass or lead free brass pocket
- **Brannan** quality and accuracy
- Durable and reliable – no moving parts
- Bottom or back connection
- For hot water and chilled water systems
- Calibration traceable to National Standards or Statement of Conformity available, if required

Standard product specifications:

Case	183mm steel with white lacquer
Tube	Triangle tube with red liquid filling
Window	Glass
Connection	1/2" NPT
Form	Straight or 90° angle
Stem	Brass 14mm diameter x 55mm
Range	+5 to +135°C&F
Accuracy	+/- 2%

Product data sheet

✉ sales@brannan.co.uk

☎ +44 (0)1946 816600

🌐 brannan.co.uk

Dimensions - bottom entry

Dimensions - back entry

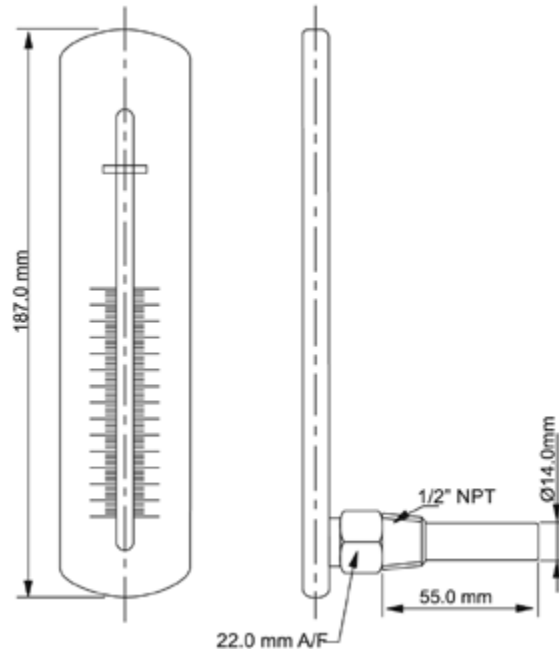
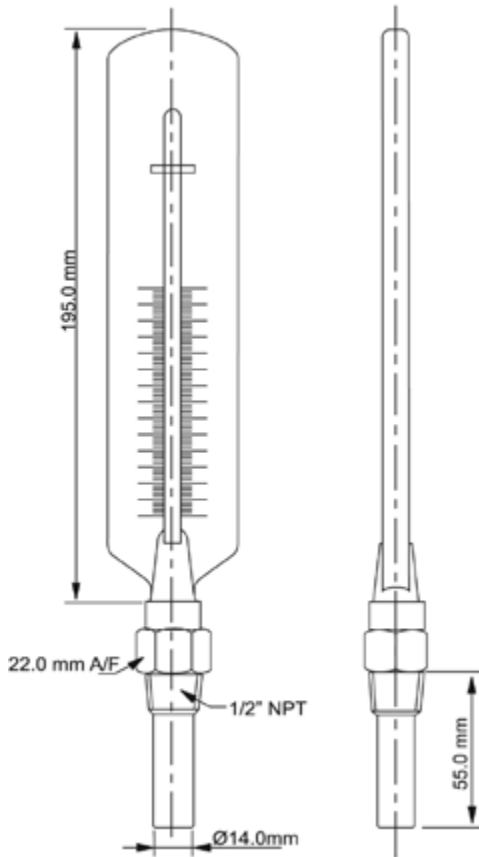

Packaging details - weight:

	Bottom conn.	Back conn.
Thermometer	282.5g	274.5g
Box	39.5g	50.5
Protective bubble	3.5g	3.5g
Total weight	325.5g	328.5g

Standard product numbers:

Connection	Range	Product no
Bottom	+5 to +135°C&F	200/001/0
Back	+5 to +135°C&F	200/002/0

View me on the website

